

“Advanced Vehicle Parking Using PLC”

Aravinda Mahapatra¹, Dipak Kumar Sahu² and Soumya Mohanty³

¹Assistant Professor, Department of Electrical Engineering, Aryan Institute of Engineering and Technology Bhubaneswar

²Assistant Professor, Department of Electrical, Raajdhani Engineering College, Bhubaneswar

³Assistant Professor, Department of Electrical Engineering, Capital Engineering College (CEC), Bhubaneswar

Abstract – The first aim of project is design an advanced vehicle parking system this system will automatically park the car without using the driver. The driver parks his car on the passage of the vehicle park. After driver selects parking space on the computer, the vehicle will transported to the parking space. In order retrieve the car, the driver selects the location of the pallet or number of vehicle on the computer. These systems will retrieving the car from parking space and then send the car in the original position while driver is waiting. Plc is used in the advanced vehicle parking system. The PLC is used to control the movement of necessary to park the car and recover the car to and from the available parking space is choose the driver. A program needs to be created for the PLC. By using in this project ladder diagram programming are used. Steeper motor or (DC) motor is used to provide the movements of transporting the car in the parking system. Then proximity sensor is detected the available parking space and also the location of the carrier.

Keywords: Dc motor, Multi floor, Programmable logic control, Proximity sensor, Relay, SMPS,

1. INTRODUCTION

In this modern world, parking of vehicles has major issue in the world. Because population is growing drastically which indirectly reduces the space available for parking. Due to this high population, traffic congestion problems have become a major issue in today's world. So it is a need to solve the parking problems and provide an efficient solution for parking of the vehicles. Advanced Car Parking is an efficient solution for traffic congestion. The design of this system is a two storey building in which the parking has no intervention of human at all. This system has not only reduces the human efforts, but also reduces the consumption of space. The advanced car parking assures full safety of vehicle and its owner. The conserved space can be used for gardening or any other purpose to make the environment pollution free. It is the structure with three floors consisting of three parking slots on which each floor can be implemented below ground level, reducing the wastages of space. The PLC used in the system for controlling the lifts, which are used for the movement of vehicles in horizontal, as well as vertical directions, floor to floor and it is done by the pneumatic cylinders. The system has advancements in aspects of security. Prototype system has helped to tackle the parking problems by reducing the struggle to search for parking slots, making it more secure and environment friendly. It is completely automated

system where the car owner does not have to take parking and imparking the car.

2. LITERATURE SURVEY

Design and Fabrication System

It uses sensors to detect the available of the vacant slots and based on the condition, if space is available or not then glows the LEDS used for the indicates the slots are vacant or not. So the green LED is indicates the vacant slot and red LED are indicates that no space is available. Not only the system is accurate but less complex Drawbacks of these system are that is requires more number of sensors. Two sensors on platform and two sensors on the floors are required which increases its cost. This system power consumption is a high. Because of this the parking charges also increases. So it is not viable to all the apartments and commercial areas as there is need of higher security aspects in such area. Also the implementation of this system is difficult and not economical. [1]

Automated Parking

Automated vehicle parking is a method of automatically parking of the cars or vehicles to solve this problem of increasing demand for safe and reliable parking and total number of vehicles is increasing in day by day. The driver will parks his car at the passage of the car park structure then car is automatically moved through the pallet and stored in a free parking space. All these are done by using the computer controlled system of the , shuttles, pallet, carriers and lifts in transporting cars from the coming up level to a parking space and vice versa without human labour. Then the car will be returned to the driver by using a signalling device outside the building. [2]

Smart Car Parking System

Opening of the gate to parking slot is its using the smart card; if space is available in the ground floor then driver will be guide to the free parking space. If space is full, then driver is leave his car in a specified place or free space and the car are shifted to parking place in the first floor using the elevator. Then car is taken out, by using the smart card. Then smart card used to opening the exit gate. Microcontrollers are used to controlling the movement of the gate. A user can record his preference through a website/ mobile app otherwise default preference is considered. A message is sent to the car owner about the parking location of the car. But the drawback of this system

is that it is not inexpensive to all companies and buildings as it would add to their cost of applying smart cards to their products which makes the implementation of the system difficult and non economic. [3]

3. DESCRIPTION OF SYSTEM

The given of the proposed system is shown in figure It consists of 2 parts; input module module, output module. PLC module is used

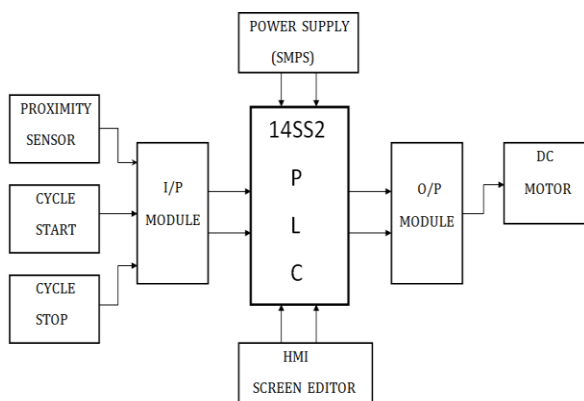

Fig -1: Block diagram of Advanced vehicle parking

HARDWARE COMPONENT

Programmable Logic Controller (PLC)

Programmable Logic Controller (PLC) is widely used compared to PC. The original PLC was just a simple on and off device. Therefore it was very suitable to replace simple relay applications. Since the early days, manufacturers of PLC have added numerous features and enhancements to PLC. Now it has the capability to handle complex tasks such as position control, process control and other difficult applications. The speed of operation and ease of programming has also improved drastically.

PLC is really an industrial computer as its hardware and software have been specifically adapted to the industrial environment. Based on the status of input signals, PLC will react by producing output signals to drive output devices like motors, relays, alarm and contactors to on or off state. This is done with a control application program stored within the PLC memory. The program will execute according to pre defined sequence of operations.

PLC is widely used in the industrial sector as it has some major advantages. First of all, the wiring of PLC is much less compared to conventional relay control system. Modification can be quite difficult with all these wiring in the conventional

Control panel. But in PLC, modification of control sequence or application can easily be done by programming through the console of PLC or computer software without the need to change the wiring if no additional input or output devices

required. Besides that, the complicated wiring in conventional system may also cause the troubleshooting to be quite troublesome. In comparison, of the PLC self diagnostic functions enable easy and fast troubleshooting of the system.

SMPS

A switched-mode power supply (switching-mode power supply, switch-mode power supply, switched power supply, SMPS, or switcher) is an electronic power supply that incorporates a switching regulator to convert electrical power efficiently. Like other power supplies, an SMPS transfers power from a DC or AC source (often mains power) to DC loads, such as a personal computer, while converting voltage and current characteristics. Unlike a linear power supply, the pass transistor of a switching-mode supply continually switches between low-dissipation, full-on and full-off states, and spends very little time in the high dissipation transitions, which minimizes wasted energy.

Ideally, a switched-mode power supply dissipates no power. Voltage regulation is achieved by varying the ratio of on-to-off time. In contrast, a linear power supply regulates the output voltage by continually dissipating power in the pass transistor. This higher power conversion efficiency is an important advantage of a switched-mode power supply. Switched-mode power supplies may also be substantially smaller and lighter than a linear supply due to the smaller transformer size and weight. Switching regulators are used as replacements for linear regulators when higher efficiency, smaller size or lighter weights are required. They are, however, more complicated; their switching currents can cause electrical noise problems if not carefully suppressed, and simple designs may have a poor power factor.

DC Motor

A DC motor is any of a class of rotary electrical machines that converts direct current electrical energy into mechanical energy. The most common types rely on the forces produced by magnetic fields. Nearly all types of DC motors have some internal mechanism, either electromechanical or electronic; to periodically change the direction of current flow in part of the motor. DC motors were the first type widely used, since they could be powered from existing direct-current lighting power distribution systems. A DC motor's speed can be controlled over a wide range, using either a variable supply voltage or by changing the strength of current in its field windings. Small DC motors are used in tools, toys, and appliances. The universal motor can operate on direct current but is a lightweight motor used for portable power tools and appliances. Larger DC motors are used in propulsion of electric vehicles, elevator and hoists, or in drives for steel rolling mills. The advent of power electronics has made replacement of DC motors with AC motors possible in many applications.

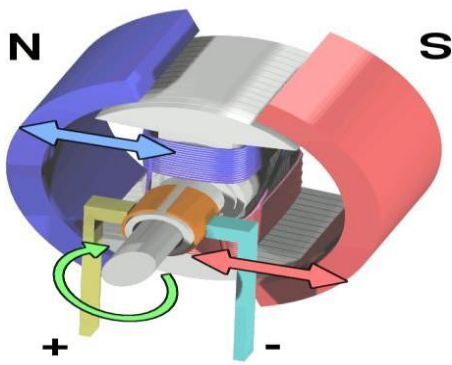

Fig -2: Construction diagram

3.4 Proximity Sensor

A proximity sensor is a sensor able to detect the presence of nearby objects without any physical contact. A proximity sensor often emits an electromagnetic field or a beam of electromagnetic radiation (infrared, for instance), and looks for changes in the field or return signal. The object being sensed is often referred to as the proximity sensor's target. Different proximity sensor targets demand different sensors. For example, a capacitive proximity sensor or photoelectric sensor might be suitable for a plastic target; an inductive proximity sensor always requires a metal target.

The maximum distance that this sensor can detect is defined "nominal range". Some sensors have adjustments of the nominal range or means to report a graduated detection distance. Some know these processes as "thermo sensation".

Proximity sensors can have a high reliability and long functional life because of the absence of mechanical parts and lack of physical contact between sensor and the sensed object. Proximity sensors are commonly used on mobile devices. When the target is within nominal range, the device lock screen UI will appear, thus emerging from what is known as sleep mode. Once the device has awoken from sleep mode, if the proximity sensor's target is still for an extended period of time, the sensor will then ignore it, and the device will eventually revert into sleep mode. For example, during a telephone call, proximity sensors play a role in detecting (and skipping) accidental touch screen taps when mobiles are held to the ear. Proximity sensors are also used in machine vibration monitoring to measure the variation in distance between a shaft and its support bearing. This is common in large steam turbines, compressors, and motors that use sleeve-type bearings.

4. RESULT



Fig -3: Project system

4.1 RESULT

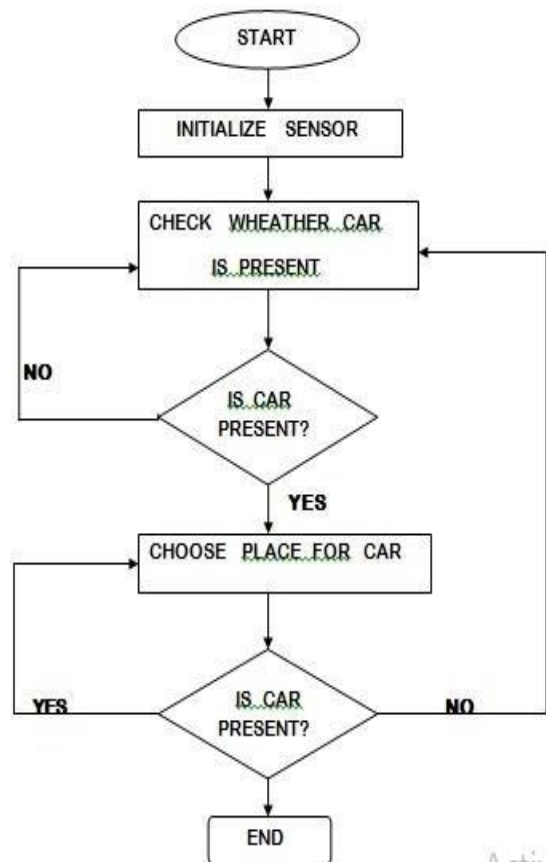

Fig -4: Flowchart of car parking

5. FUTURE SCOPE

There are basically some points we are considering in the future scope of our project. Firstly, we replace it by conventional 3 floor or 4-floor parking systems in the residential and corporate building with our advanced car parking system. And secondly, we see our project can be built in collaboration with the construction of 5 and 7-star hotels, molls to accommodate our parking system in the building itself so as the luxury cars can be fitted with the suite of the executive lounges. We are working to develop the project and research on the same. Also, we have developed it by using the plc

6. CONCLUSION

By using PLC, we can manage number of the cars inside the parking area easily. We can reduce the time to park the Cars and saves the fuel. It can easily detect the free space and park the car. By using PLC we can monitor the parking System.

7. ACKNOWLEDGMENT

We would like to sincerely thank Mrs Chorge P. I, HOD, electronics and telecommunication department and our project guide Nadaf N.S sir, Assistant Professor, electronics I and telecommunication department, DACOE College for their valuable support and help in this research.

6. REFERENCES

[1] Sandeep Saini¹, Rishikesh Mishra²Amol avhad³,Sudarshan Avhad⁴,Vikram Algat, A Project Report on Automatic Car Parking System, International Journal of Emerging Technology and Advanced Engineering ISSN 2250-2459, Volume 7, Issue 4, April 2017.

[2] Chirag Agrawal¹ Balvindra² Abhay Kumar³ Ashish Pal⁴ Mrs. Alka Verma⁵, automatic vehicle Parking using PLC , International Journal for Technological Studies| Vol. 3, Issue 6, May 2016 | ISSN (online): 2348-1439

[3]Amol Pawar, Rahul Rane, Pritam Raut, Dhanshri Mulepatil, Anubha Panchal, AUTOMATIC MULTILEVEL CAR PARKING & CONTROLLING SYSTEM USING PLC, International Research Journal of Engineering and Technology (IRJET) e-ISSN: 2395 -0056 Volume: 04 Issue: 03 | Mar -2017.